

High performance electric forklift with enclosed, twin AC motor front wheel drive

5 individually adjustable working programs

Comfortable workstation with SOLO- or MULTI-PILOT control (optional)

Jungheinrich Curve Control for safer driving and cornering

Maintenance-free multiple disc brakes



EFG 213–220

Electric three-wheel forklift truck (1300, 1500, 1600, 1800, 2000 kg)

The use of innovative three-phase AC technology opens up new possibilities and provides numerous advantages for electric forklift trucks:

- Excellent performance values for acceleration, travel and lift speeds allow for maximum productivity.
- More work per battery charge as a result of optimum efficiency and more effective energy recovery.
- Precise hydrostatic power steering and solid-state electric braking when the accelerator is released.

- Maintenance-free brushless enclosed three phase AC motors protected to IP 54.

This ensures faster working cycles and significantly longer operation per battery charge. Low day-to-day operating costs, together with reduced maintenance requirements, guarantee outstanding economic efficiency.

Compact design makes the three wheel truck extremely manoeuvrable and allows fast operation in the most confined spaces

for example lorries, containers or railway wagons. The closed design and the front wheel drive ensure a universal suitability and optimal traction on gradients and slippery surfaces.

EFG 213–220

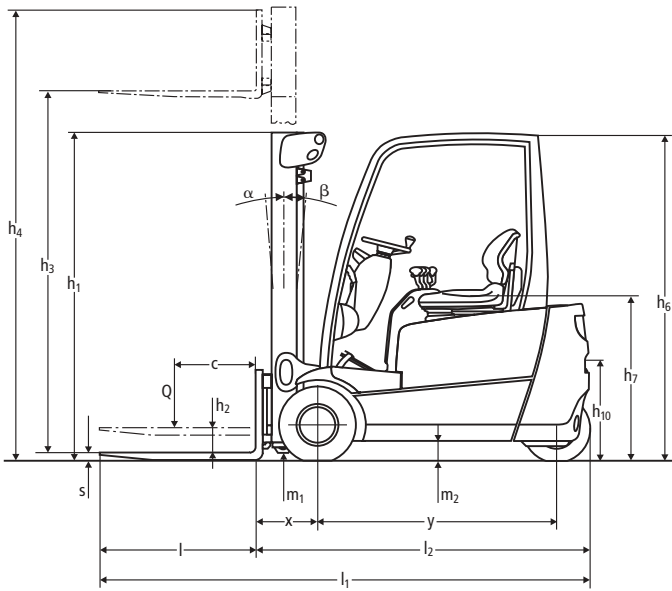

Capacity

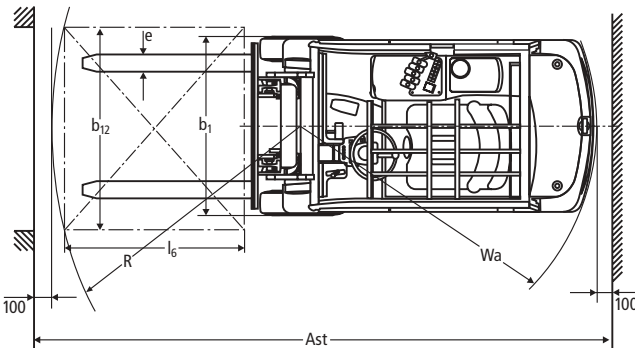
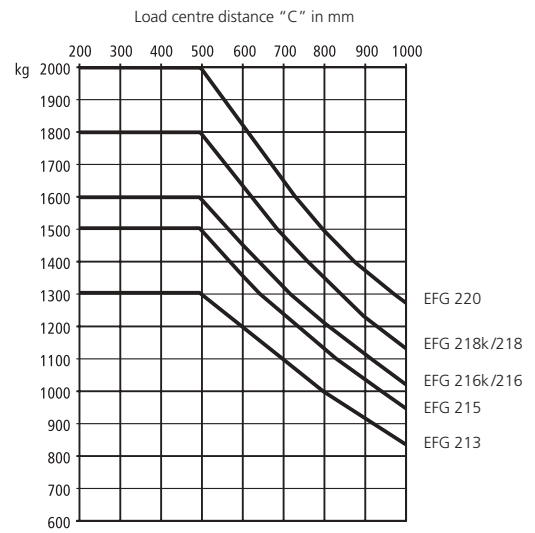

Designation	Lift height h_3 mm	Free lift h_2 mm		Closed mast height h_1 mm	Extended mast height h_4 mm		Forward/ backward tilt α/β (°)	Capacity table (kg) $c = 500$ mm without sideshift, single solid tyres				
		EFG 213–216	EFG 218–220		EFG 213–216	EFG 218–220		EFG 213	EFG 215	EFG 216k/216	EFG 218k/218	EFG 220
		Two-stage ZT	2300		150	150		1650	2860	2887	7/4	1300
	3000	150	150	2000	3560	3587	7/7	1300	1500	1600	1800	2000
	3100	150	150	2050	3660	3687	7/7	1300	1500	1600	1800	2000
	3300	150	150	2150	3860	3887	7/7	1300	1500	1600	1800	2000
	3600	150	150	2300	4160	4187	7/7	1300	1500	1600	1800	2000
	4000	150	150	2500	4560	4587	7/7	1300	1500	1600	1800	2000
	4500	150	150	2800	5060	5087	7/7	1300	1500	1600	1800	2000
	5000	150	150	3050	5560	5587	7/5	1200	1400	1500	1700	1850
	5500*	150	150	3400	6060	6087	7/5	1100	–	1400	1550	1650
Two-stage ZZ	2300	1045	988	1605	2860	2917	7/4	1300	1500	1600	1800	2000
	3000	1395	1338	1955	3560	3617	7/7	1300	1500	1600	1800	2000
	3100	1445	1388	2005	3660	3717	7/7	1300	1500	1600	1800	2000
	3300	1545	1488	2105	3860	3917	7/7	1300	1500	1600	1800	2000
	3600	1695	1638	2255	4160	4217	7/7	1300	1500	1600	1800	2000
	4000	1895	1838	2455	4560	4617	7/7	1300	1500	1600	1800	2000
Three-stage DZ	4350	1395	1338	1955	4910	4967	7/7	1300	1500	1600	1800	2000
	4500	1445	1388	2005	5060	5117	7/7	1300	1450	1600	1800	2000
	4800	1545	1488	2105	5360	5417	7/6	1250	1400	1550	1700	1900
	5000	1620	1563	2180	5560	5617	7/6	1200	1350	1500	1650	1800
	5500	1795	1738	2355	6060	6117	7/5	1050	1250	1350	1500	1600
	6000*	1995	1938	2555	6560	6617	7/5	900	–	1150	1300	1400
	6500*	2245	2188	2805	7060	7117	7/5	750	–	950	1100	1150

* Mast not available for EFG 215

Technical Data in line with VDI 2198 as at: 09/2005

		Jungheinrich		Jungheinrich		Jungheinrich		Jungheinrich					
		EFG 213	EFG 215	EFG 216k	EFG 216	EFG 218k	EFG 218	EFG 220					
Identification	1.1	Manufacturer (abbreviation)		Jungheinrich		Jungheinrich		Jungheinrich	1.1				
	1.2	Manufacturer's type designation		EFG 213	EFG 215	EFG 216k	EFG 216	EFG 218k	EFG 218	EFG 220	1.2		
	1.3	Drive: electric (battery or mains), diesel, petrol, fuel gas, manual		electric		electric		electric		electric	1.3		
	1.4	Type of operation: hand, pedestrian, standing, seated, order picker		seated		seated		seated		seated	1.4		
	1.5	Load capacity / rated load	Q (t)	1.3	1.5	1.6		1.8		2.0	1.5		
	1.6	Load centre distance	c (mm)	500		500		500		500	1.6		
	1.8	Load distance, centre of drive axle to fork	x (mm)	347 ¹⁾		352 ²⁾		352 ²⁾		352 ²⁾	1.8		
	1.9	Wheelbase	y (mm)	1249		1357	1465	1357	1465	1465	1.9		
	Weights	2.1	Service weight incl. battery (see line 6.5)	kg	2800	2990	2990	3185	3100	3170	3205	2.1	
2.2		Axle loading, laden front/rear	kg	3490/610	3930/560	4015/575	4030/755	4415/485	4375/595	4665/540	2.2		
2.3		Axle loading, unladen front/rear	kg	1310/1490	1415/1575	1410/1580	1500/1685	1485/1615	1530/1640	1500/1705	2.3		
Wheels, Chassis	3.1	Tyres: solid rubber, superelastic, pneumatic, polyurethane		SE(L)/SE(L)		SE(L)/SE(L)		SE/SE		SE/SE	3.1		
	3.2	Tyre size, front		18x7-8		18x7-8		200/50-10		200/50-10	3.2		
	3.3	Tyre size, rear		140/55-9		140/55-9		140/55-9		140/55-9	3.3		
	3.5	Wheels, number front rear (x = driven wheels)		2x2		2x2		2x2		2x2	3.5		
	3.6	Track width, front	b ₁₀ (mm)	904		904		914		914	3.6		
	3.7	Track width, rear	b ₁₁ (mm)	176		176		176		176	3.7		
	Basic Dimensions	4.1	Mast/fork carriage tilt forward/backward		7/7		7/7		7/7		7/7	4.1	
4.2		Lowered mast height		2000		2000		2000		2000	4.2		
4.3		Free lift		150		150		150		150	4.3		
4.4		Lift height		3000		3000		3000		3000	4.4		
4.5		Extended mast height		3560		3560		3587		3587	4.5		
4.7		Overhead load guard (cab) height		1960		1960		1960		1960	4.7		
4.8		Seat height/standing height		890		890		890		890	4.8		
4.12		Coupling height		560		560		560		560	4.12		
4.19		Overall length		2936		3049	3157	3049	3157	3157	4.19		
4.20		Length to face of forks		1786		1899	2007	1899	2007	2007	4.20		
4.21		Overall width		1060/-		1060/-		1120/-		1120/-	4.21		
4.22		Fork dimensions		s/e/l (mm)		35x100x1150		40x100x1150		40x100x1150	4.22		
4.23		Fork carriage ISO 2328, class/type A, B		2A		2A		2A		2A	4.23		
4.24		Fork-carriage width		980		980		980		980	4.24		
4.31		Ground clearance, laden, under mast		90		90		90		90	4.31		
4.32		Ground clearance, centre of wheelbase		100		100		100		100	4.32		
4.33		Aisle width for pallets 1000x1200 crossways		Ast (mm)		3115	3224	3334	3224	3334	3334	4.33	
4.34		Aisle width for pallets 800x1200 lengthways		Ast (mm)		3238	3348	3458	3348	3458	3458	4.34	
4.35		Turning radius		Wa (mm)		1440	1545	1655	1545	1655	1655	4.35	
4.36	Smallest pivot point distance		b ₁₃ (mm)		0		0		0	0	4.36		
Performance Data	5.1	Travel speed, laden/unladen		km/h		16.0		16.0		16.0	5.1		
	5.2	Lift speed, laden/unladen		m/s		0.48/0.60	0.46/0.60	0.46/0.60	0.38/0.50	0.38/0.50	5.2		
	5.3	Lowering speed, laden/unladen		m/s		0.55		0.55		0.55	5.3		
	5.5	Drawbar pull, laden/unladen S ₂ 60 min		N		2300/2500	2200/2450	2150/2450	2100/2450	2000/2300	1900/2300	5.5	
	5.6	Max. drawbar pull, laden/unladen S ₂ 5 min		N		12700/12700		12700/12700		12400/12200	12300/12000	5.6	
	5.7	Gradient performance, laden/unladen S ₂ 30 min		%		7.6/12.5	7.3/12.3	7.3/12.3	7.0/11.5	6.2/10.7	5.9/10.5	5.7/10.4	5.7
	5.8	Max. gradient performance, laden/unladen S ₂ 5 min		%		28.0/35.0	27.0/35.0	27.0/35.0		26.0/35.0	25.0/35.0	24.0/35.0	5.8
	5.9	Acceleration time, laden/unladen 10 m		s		3.6/3.2	3.8/3.4	3.8/3.4		3.9/3.5	4.0/3.5	5.9	
	5.10	Service brake				hydr./electr.		hydr./electr.		hydr./electr.	hydr./electr.	5.10	
	E-Motor	6.1	Drive motor rating S ₂ 60 min		kW		4.0/4.0		4.0/4.0		4.0/4.0	6.1	
6.2		Lift motor rating at S ₃ 15 %		kW		10.0		10.0		10.0	6.2		
6.3		Battery acc. to DIN 43531 / 35/36 A, B, C, no				DIN 43531 A		DIN 43531 A	DIN 43531 A	DIN 43531 A	DIN 43531 A	6.3	
6.4		Battery voltage, nominal capacity K _s		V/Ah		48/460		48/575	48/690	48/575	48/690	48/690	6.4
6.5		Battery weight		kg		715		855	1025	855	1025	1025	6.5
6.6		Battery dimensions l/w/h		cm		830/522/627		830/630/627	830/738/627	830/630/627	830/738/627	830/738/627	6.6
Other Details	8.1	Type of drive control				Impulse/AC		Impulse/AC		Impulse/AC	Impulse/AC	8.1	
	8.2	Operating pressure for attachments		bar		approx. 200		approx. 200		approx. 200	approx. 200	8.2	
	8.3	Oil volume for attachments		l/min		25		25		25	25	8.3	
	8.4	Sound level at driver's ear according to DIN 12053		dB(A)		66		66		66	66	8.4	
	8.5	Tow coupling, type DIN				15170/type H		15170/type H		15170/type H	15170/type H	8.5	

1) 372 mm with DZ mast, with integrated sidishift: x = 370 mm (395 mm with DZ mast), with sidishift attachment: x = 405.5 mm (425.5 mm with DZ mast)

2) 377 mm with DZ mast, with integrated sidishift: x = 375 mm (400 mm with DZ mast), with sidishift attachment: x = 410.5 mm (435.5 mm with DZ mast)

3) 45 VDI working cycles/h

This specification sheet according to VDI regulation 2198 only provides technical values for the standard truck. Non-standard tyres, different masts, additional equipment, etc. could produce other values. Right reserved for technical changes and improvements.

Make use of the advantages

Superior operator comfort

Functionality and ergonomics of the driver compartment guarantees relaxed and fatigue-free work over long shifts:

- Low access step. Large, level foot well with automotive pedal lay-out.
- Adjustable steering column and hydraulic comfort seat for optimum seating position.
- Floating cab module cushions road shocks and vibrations.
- Clear view: mast and fork carriage allow for excellent visibility to load and road.
- Hydraulic power steering is precise and low effort, without kick-back.



SOLO-PILOT

- Comfort Display provides up-to-date information on vital vehicle conditions at a glance.
- Comfortable, fatigue-free operation of direction and hydraulics by SOLO-PILOT control (separate levers) or MULTI-PILOT control (optional), all functions controlled by one lever.
- Convenient storage for documents and the operators belongings.

Safe, wear-free braking

Three distinct systems ensure safe, precise and largely wear-free braking:

- Regenerative electric braking in reversing mode and regular brake pedal use.



MULTI-PILOT

- Multiple oil disc brakes act as a safety back-up. Wear-free and fully enclosed.
- Parking brake uses the service brake system through a separate electric actuation system. Operation warning light in the drivers console.

Maintenance free electric motors

Proven AC technology: 2 drive motors, hydraulic pump motor, steering motor. High performance, low energy consumption, less maintenance:

- High torque for rapid work cycles.
- Up to 15% higher energy efficiency than shunt motors.
- No brushes, no collector – no maintenance expense.
- Fully enclosed and protected to IP 54. Long life, even under dusty and damp conditions.
- 2 years warranty on all motors.

Active safety

Excellent drive dynamics and performance also demand a high degree of safety:

- Curve Control automatically reduces travel speed when cornering.
- Rollback protection ensures controlled operation on ramps and slopes.
- Very low centre of gravity improves stability and residual capacity.

- Twin wheel steering axle with low profile tyres ensures stable handling and smooth travel.
- Electronic and hydraulic overload protection guard.
- Traction Control ensures optimum torque in curves.
- Emergency cut off switch quickly accessible.
- Reliable data transfer between electronic components through CAN-Bus technology.

Intelligent electronics

BoardControl electronic system permanently controls and monitors all truck functions.

- Smooth driving, dynamic reversing and precise load positioning with a minimum of energy.



Comfort Display

- 5 application programs can be individually adapted to ensure optimal performance in any application.
- Diagnostic system monitors all components and provides service data memory for rapid and cost-effective maintenance.
- Comfort Display with digital service hour meter (actual or cyclic duration factor), battery discharge indicator plus lift cut-out, clock, error code and warning displays.
- Electronic steer wheel position indicator.

Jungheinrich UK Ltd.

Head Office:

Sherbourne House
 Sherbourne Drive
 Tilbrook
 Milton Keynes MK7 8HX
 Telephone 01908 363100

info@jungheinrich.co.uk
 www.jungheinrich.co.uk

ISO 9001, ISO 14001
 Certification of Quality and
 Environment Management.



Jungheinrich trucks
 conform to the European
 Safety Requirements.



JUNGHEINRICH
Well worthwhile